

XDS Breakpoint/Trace Installation and Operation Guide

XDS Extended Development Support



PREFACE

The purpose of this manual is to familiarize the user with the functions and theory of the Breakpoint/Trace board. The Breakpoint/Trace Board is an optional circuit card for the XDS that greatly increases the capabilities of the system. This manual also describes installation instructions for the Breakpoint/Trace board, part numbers 2311045-0001 and 2311045-0002. The user and installer should read this manual before attempting to operate or install the Breakpoint/trace board. If the Breakpoint/Trace board is removed from the XDS, this manual should be kept with the board for reference during future installation.

LIST of TABLES

Table	Title	Page
1-1	Breakpoint/Trace Board Configurations	1-2
1-2	Chassis Configuraiton Label Information	1-4
2-1	Extended Trace Probe Color Code	2-2
2-2	Breakpoint/Trace DC Power Requirements	2-2

TABLE of CONTENTS

Paragraph	Title	Page
-----------	-------	------

PREFACE

SECTION 1 INSTALLATION

1.1	INTRODUCTION	1-1
1.1.1	Board Preparation and Installation	1-1
1.1.1.1	Board Configuration	1-1
1.1.2	Board Installation	1-2
1.1.2.1	Extended Trace Cable Installation	1-4
1.1.2.2	Installation Completion	1-4

SECTION 2 HARDWARE FEATURES

2.1	INTRODUCTION	2-1
2.1.1	Status Indicator Lights	2-1
2.1.2	Extended Trace Probe	2-1
2.1.3	Power Requirements	2-1

SECTION 3 THEORY OF OPERATION

3.1	INTRODUCTION	3-1
3.1.1	Break Point Capability	3-1
3.1.2	Tracing Capability	3-1
3.1.3	Block Diagram	3-1

APPENDIX A Breakpoint/Trace Board Schematics

LIST of FIGURES

Figure	Title	Page
1-1	Breakpoint/Trace Board PN 2311045	1-3
3-1	Breakpoint/trace Board Block Diagram	3-2

SECTION 1

INSTALLATION

1.1 INTRODUCTION

The breakpoint/Trace board is an option that significantly increases the emulating power of the XDS, (Extended Development Support System). Some of this increased performance includes being able to set a breakpoint on any memory access (read or write), breakpoint on an instruction opcode, and breakpoint on any I/O or CRU (Communications Register Unit) access (address and data can be specified). Also, the Breakpoint/Trace board allows the user to trace the execution of a system under test by storing all the necessary information of address and/or data in memory, and then displaying it after stopping at a breakpoint. More information on the use of the breakpoint/trace board is available in the emulator user's guide. Refer to this section if the board is not installed or if it is to be moved. Also refer to this section if you wish to change the board options.

1.1.1 Board Preparation and Installation.

The Breakpoint/Trace board can be configured so that it can support the major portion of the XDS system emulators. When installing the breakpoint/trace board you should check the type of emulator it is being used with to determine if a conversion is required.

1.1.1.1 Board Configuration.

The Breakpoint/Trace board is available in two configurations. Table 1-1 describes which configuration is used with each emulator system. The part number of the breakpoint/trace board determines how the board is configured and which emulators it will support. You should be sure and update the board's part number if the configuration of the board is changed. The board may be field converted from a 2311045-0001 to a 2311045-0002 by changing the 74ALS573 devices in locations U3 through U8 to 74ALS574 devices. Of course a 2311045-0002 may be converted to a 2311045-0001. Table 1-1 describes which devices are used on each configuration of the board. The location of the devices are shown in Figure 1-1 and they are installed in sockets

so no soldering is required.

Table 1-1 Breakpoint/Trace Board Configurations

Part Number	Emulator Type	Device Type Locations U3 - U8
2311045-0001	TMS7000	74ALS573
2311045-0001	TMS9995	74ALS573
2311045-0002	TMS32010	74ALS574
2311045-0002	TMS99000	74ALS574

1.1.2 Board Installation.

CAUTION

BEFORE INSTALLING OR REMOVING ANY BOARD, TURN OFF THE POWER TO THE XDS UNIT.

The XDS Model XX Installation and Operation Guide describes the procedure for installing or removing boards from the XDS unit. Refer to the manual appropriate for the XDS Model you are using. If an breakpoint/trace board is currently installed in the XDS it must be removed before another one can be installed. Only one breakpoint/trace board can be installed at any one time for the XDS to function properly. The breakpoint/trace board must be installed in slot number 1.

Boards removed from the chassis should be stored so that they are protected from static discharge. Erase the board information on the chassis configuration label for each circuit board removed.

For the Breakpoint/Trace board enter the following information on the chassis configuration label for slot number 1 as given in Table 1-2.

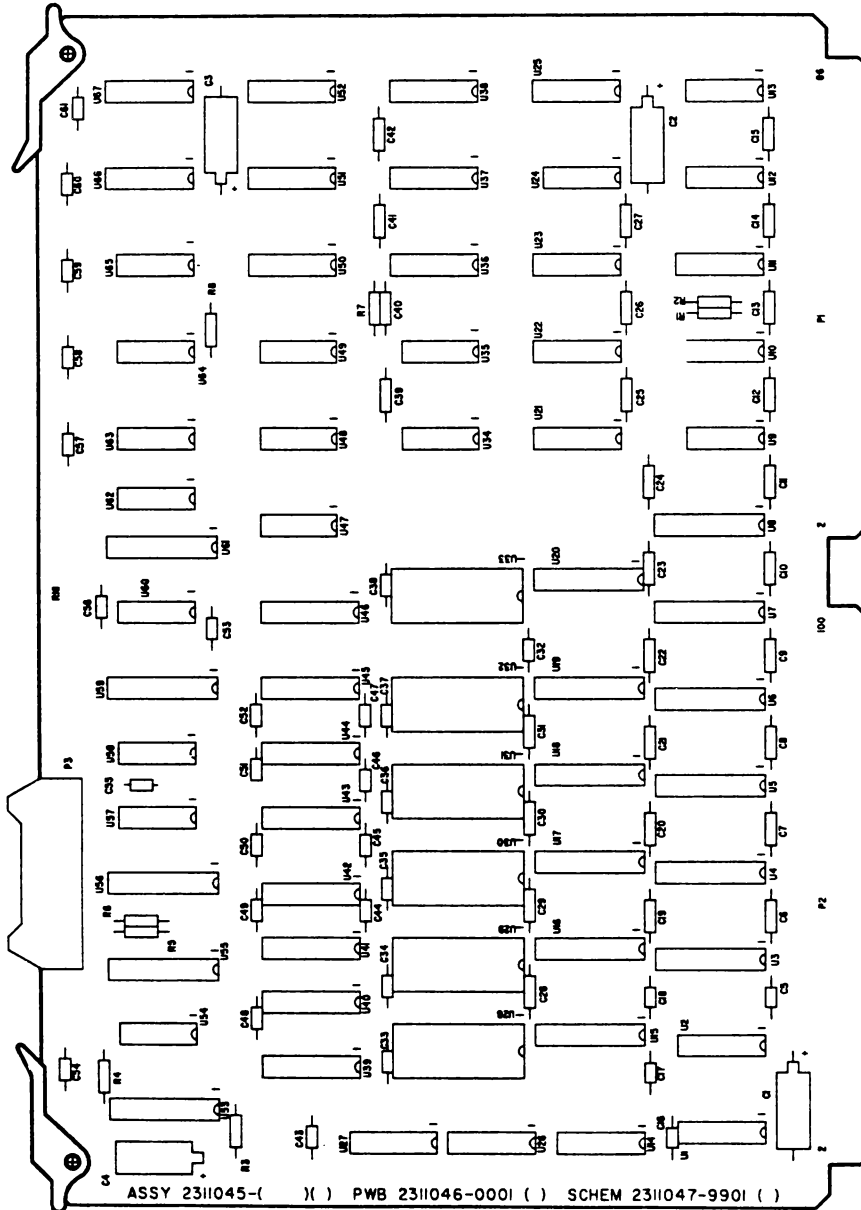

Figure 1-1 Breakpoint/Trace Board PN 2311045

Table 1-2 Chassis Configuraiton Label Information

Block Title	Information to be Entered
PWB Description	BREAKPOINT/TRACE
Part No	2311045-0001 OR 2311045-0002
REV	ENTER REVISION LETTER FROM BREAKPOINT/TRACE BOARD.

1.1.2.1 Extended Trace Cable Installation.

To complete the installation of the breakpoint/trace board the extended trace cable (PN 2232136-0001) must be installed. This cable plugs into the board via connector P3 on the edge of the board. Refer to Figure 1-1 for the location of P3. Note that the extended trace cable is held in place by the target cable clamp and that this clamp must be removed before installing or removing the breakpoint/trace board. When the extended trace cable has been installed, restore the target cable clamp to its position to secure the extended trace cable. Refer to the appropriate XDS installation and operation manual for instructions on installing the target cable clamp.

The extended trace cable has an extended trace probe (PN 2232139-0001) which plugs on to the end of the cable. This probe may be connected or disconnected at any time during an operating session. You may find it desirable to disconnect the probe when it is not in use or to move the target system. When the Probe is disconnected it should be kept in a safe place.

1.1.2.2 Installation Completion.

Complete the installation according to the information in the appropriate XDS installation and operation Guide.

CAUTION

DO NOT OPERATE THE XDS UNIT WITH THE FRONT PANEL REMOVED. THE FRONT PANEL IS REQUIRED FOR PROPER AIR CIRCULATION AND COOLING OF THE CIRCUIT BOARDS. THE FRONT PANEL IS ALSO REQUIRED TO PREVENT LEAKAGE OF RFI/EMI RADIATION.

Restore power to the XDS unit. Refer to the appropriate emulator user's guide for further instructions on operating the XDS.

SECTION 2

HARDWARE FEATURES

2.1 INTRODUCTION

The breakpoint/trace board operates primarily with the emulator software that is referenced in the appropriate emulator user's guide. Also the features and applications of the extended trace cable are discussed in the emulators user's guide. The status lights and power requirements are discussed below for the breakpoint/trace board.

2.1.1 Status Indicator Lights.

The XDS has four status indicator lights that are located on the front panel of the XDS. The Breakpoint/Trace board is required for status light number one to function. The meaning of this light may differ for different emulators but the breakpoint/trace board controls it. If the breakpoint/trace board is not installed this light will not operate.

2.1.2 Extended Trace Probe.

The extended trace probe is color coded to enable you to keep track of each line. Table 2-1 relates the color code to data bit numbers.

2.1.3 Power Requirements.

The DC power requirements for the Breakpoint/Trace board are given in Table 2-2. This information may be used to calculate the total DC power requirements of the XDS system. When adding new boards to the system this DC Power calculation should be made to ensure that the XDS power supply will not be overloaded. Refer to the XDS Installation and Operation Manual for the power supply rating information, and the power requirements for the other circuit boards may be obtained from their appropriate reference manuals.

Table 2-1 Extended Trace Probe Color Code

Data Bit	Number	Color of Line
MSB	7	Violet
	6	Blue
	5	Green
	4	Yellow
	3	Orange
	2	Red
	1	Brown
LSB	0	Black
Ground		White

Table 2-2 Breakpoint/Trace DC Power Requirements

+ 5 VOLTS (AMPS)	+ 12 VOLTS (AMPS)	- 12 VOLTS (AMPS)
2.00	0	0

SECTION 3

THEORY OF OPERATION

3.1 INTRODUCTION

The breakpoint/trace board can be separated into two basic sections: Break Point capability, and Tracing capability. This section will briefly discuss these capabilities and show a block diagram of the breakpoint/trace board.

3.1.1 Break Point Capability.

A break point is a hardware interrupt which causes emulator control to be passed back to the user, and is used to stop the emulator when it has been put into execution mode. You must set up the breakpoint options before executing a program. On power up the emulators disables the breakpoint/trace board until the user issues a breakpoint or trace command to initialize the breakpoint/trace board.

3.1.2 Tracing Capability.

The trace capability provides a record of the machine cycles that occurred during the execution of a program. Each machine cycle, when it qualifies is stored in the trace buffer so that it can be recalled for examination at a later time.

3.1.3 Block Diagram.

Figure 3-1 shows a block diagram of the breakpoint trace board. The major blocks are the trace memory and the data bus.

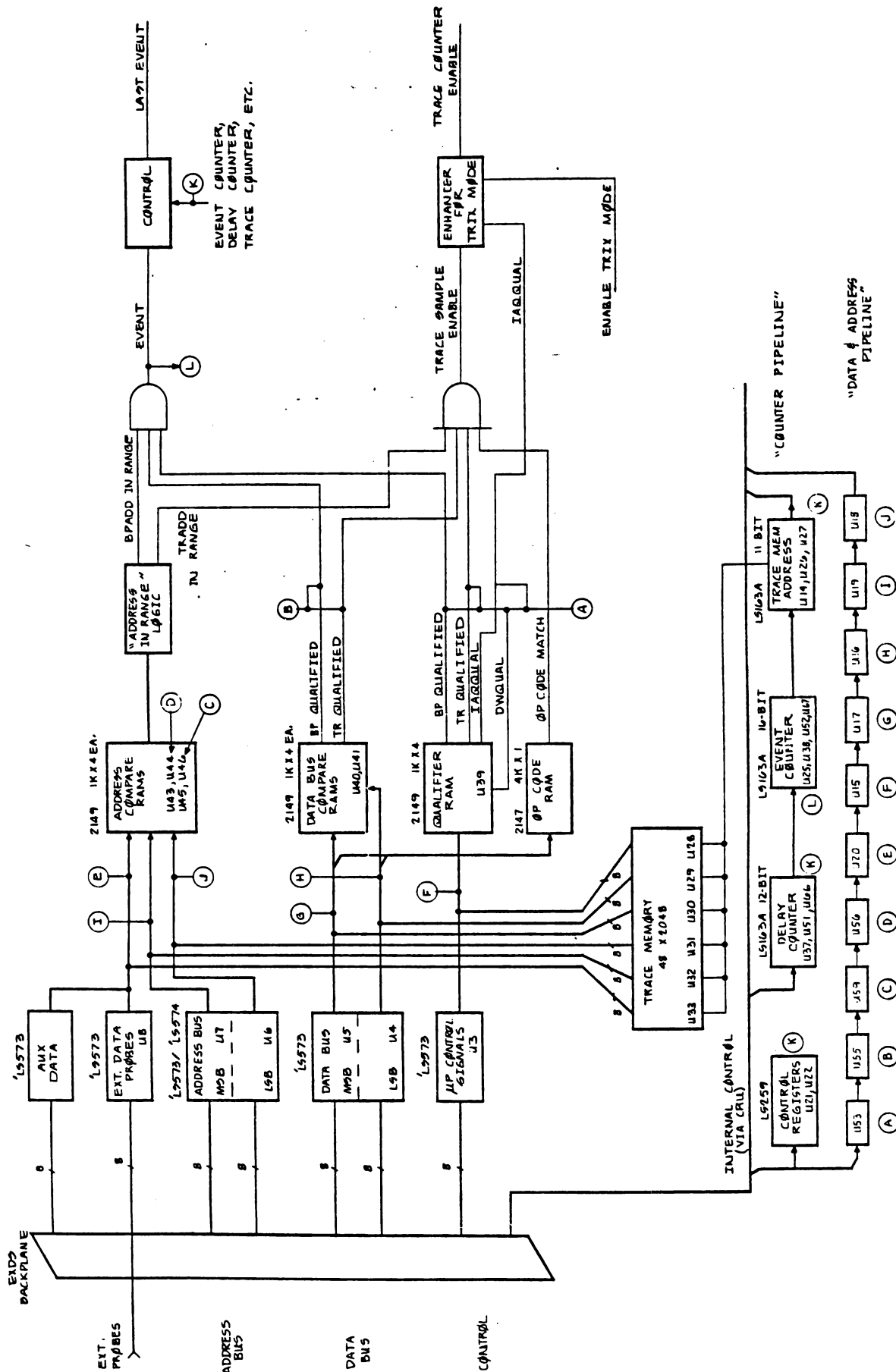

Figure 3-1 Breakpoint/trace Board Block Diagram
19 OCTOBER 1983

APPENDIX A
Breakpoint/Trace Board Schematics

2311047

3

4

5

6

7

8

- NOTES UNLESS OTHERWISE SPECIFIED:
1. ALL DEVICE TYPES ARE PREFIXED WITH SM74.
 2. VCC IS APPLIED TO PIN 6 OF ALL 8-PIN IC'S, PIN 14 OF ALL 14-PIN IC'S, PIN 20 OF ALL 20-PIN IC'S, ETC.
 3. GROUND IS APPLIED TO PIN 4 OF ALL 8-PIN IC'S, PIN 7 OF ALL 14-PIN IC'S, PIN 6 OF ALL 16-PIN IC'S, PIN 10 OF ALL 20-PIN IC'S, ETC.
 4. DEVICE TYPE, PIN NUMBERS, AND REFERENCE DESIGNATOR OF IC IS SHOWN AS FOLLOWS:



- LS00 AND LS04 = DEVICE TYPE
 U2, AND U3 = PIN NUMBERS
 U2, AND U4 = REFERENCE DESIGNATOR
 5. RESISTANCE VALUES ARE IN OHMS.
 6. RESISTOR VALUES ARE IN OHMS.
 7. CAPACITANCE VALUES ARE IN MICROFARADS.
 8. U1, U2, U10 AND U11 ARE OPEN IC LOCATIONS.
 9. MSB/LSB DEFINITIONS:
 A00 = MSB
 DB00 = MSB
 A15 = LSB
 DB15 = LSB

D

C

A-3

B

A

REV	DATE	BY	CHK	NO	DESCRIPTION	NOTE
1					CLASSIFICATION	
2					FOR CORRECTION TO DRAWING SPECIFICATIONS SET DRAWING 73487	
3						
4						
5						
6						
7						
8						
9						
10						
11						

REV	DATE	BY	CHK	NO	DESCRIPTION	NOTE
1					CLASSIFICATION	
2					FOR CORRECTION TO DRAWING SPECIFICATIONS SET DRAWING 73487	
3						
4						
5						
6						
7						
8						
9						
10						
11						

REV	DATE	BY	CHK	NO	DESCRIPTION	NOTE
1					CLASSIFICATION	
2					FOR CORRECTION TO DRAWING SPECIFICATIONS SET DRAWING 73487	
3						
4						
5						
6						
7						
8						
9						
10						
11						

REV	DATE	BY	CHK	NO	DESCRIPTION	NOTE
1					CLASSIFICATION	
2					FOR CORRECTION TO DRAWING SPECIFICATIONS SET DRAWING 73487	
3						
4						
5						
6						
7						
8						
9						
10						
11						

REV	DATE	BY	CHK	NO	DESCRIPTION	NOTE
1					CLASSIFICATION	
2					FOR CORRECTION TO DRAWING SPECIFICATIONS SET DRAWING 73487	
3						
4						
5						
6						
7						
8						
9						
10						
11						

REV	DATE	BY	CHK	NO	DESCRIPTION	NOTE
1					CLASSIFICATION	
2					FOR CORRECTION TO DRAWING SPECIFICATIONS SET DRAWING 73487	
3						
4						
5						
6						
7						
8						
9						
10						
11						

REV	DATE	BY	CHK	NO	DESCRIPTION	NOTE
1					CLASSIFICATION	
2					FOR CORRECTION TO DRAWING SPECIFICATIONS SET DRAWING 73487	
3						
4						
5						
6						
7						
8						
9						
10						
11						

REV	DATE	BY	CHK	NO	DESCRIPTION	NOTE
1					CLASSIFICATION	
2					FOR CORRECTION TO DRAWING SPECIFICATIONS SET DRAWING 73487	
3						
4						
5						
6						
7						
8						
9						
10						
11						

REV	DATE	BY	CHK	NO	DESCRIPTION	NOTE
1					CLASSIFICATION	
2					FOR CORRECTION TO DRAWING SPECIFICATIONS SET DRAWING 73487	
3						
4						
5						
6						
7						
8						
9						
10						
11						

REV	DATE	BY	CHK	NO	DESCRIPTION	NOTE
1					CLASSIFICATION	
2					FOR CORRECTION TO DRAWING SPECIFICATIONS SET DRAWING 73487	
3						
4						
5						
6						
7						
8						
9						
10						
11						

REV	DATE	BY	CHK	NO	DESCRIPTION	NOTE
1					CLASSIFICATION	
2					FOR CORRECTION TO DRAWING SPECIFICATIONS SET DRAWING 73487	
3						
4						
5						
6						
7						
8						
9						
10						
11						

REV	DATE	BY	CHK	NO	DESCRIPTION	NOTE
1					CLASSIFICATION	
2					FOR CORRECTION TO DRAWING SPECIFICATIONS SET DRAWING 73487	
3						
4						
5						
6						
7						
8						
9						
10						
11						

REV	DATE	BY	CHK	NO	DESCRIPTION	NOTE
1					CLASSIFICATION	
2					FOR CORRECTION TO DRAWING SPECIFICATIONS SET DRAWING 73487	
3						
4						
5						
6						
7						
8						
9						
10						
11						

REV	DATE	BY	CHK	NO	DESCRIPTION	NOTE
1					CLASSIFICATION	
2					FOR CORRECTION TO DRAWING SPECIFICATIONS SET DRAWING 73487	
3						
4						
5						
6						
7						
8						
9						
10						
11						

REV	DATE	BY	CHK	NO	DESCRIPTION	NOTE
1					CLASSIFICATION	
2					FOR CORRECTION TO DRAWING SPECIFICATIONS SET DRAWING 73487	
3						
4						
5						
6						
7						
8						
9						
10						
11						

REV	DATE	BY	CHK	NO	DESCRIPTION	NOTE
1					CLASSIFICATION	
2					FOR CORRECTION TO DRAWING SPECIFICATIONS SET DRAWING 73487	
3						
4						
5						
6						
7						
8						
9						
10						
11						

REV	DATE	BY	CHK	NO	DESCRIPTION	NOTE
1					CLASSIFICATION	
2					FOR CORRECTION TO DRAWING SPECIFICATIONS SET DRAWING 73487	
3						
4						
5						
6						
7						
8						
9						
10						
11						

REV	DATE	BY	CHK	NO	DESCRIPTION	NOTE
1					CLASSIFICATION	
2					FOR CORRECTION TO DRAWING SPECIFICATIONS SET DRAWING 73487	
3						
4						
5						
6						
7						
8						
9						
10						
11						

REV	DATE	BY	CHK	NO	DESCRIPTION	NOTE
1					CLASSIFICATION	
2					FOR CORRECTION TO DRAWING SPECIFICATIONS SET DRAWING 73487	
3						
4						
5						
6						
7						
8						
9						
10						
11						

REV	DATE	BY	CHK	NO	DESCRIPTION	NOTE
1					CLASSIFICATION	

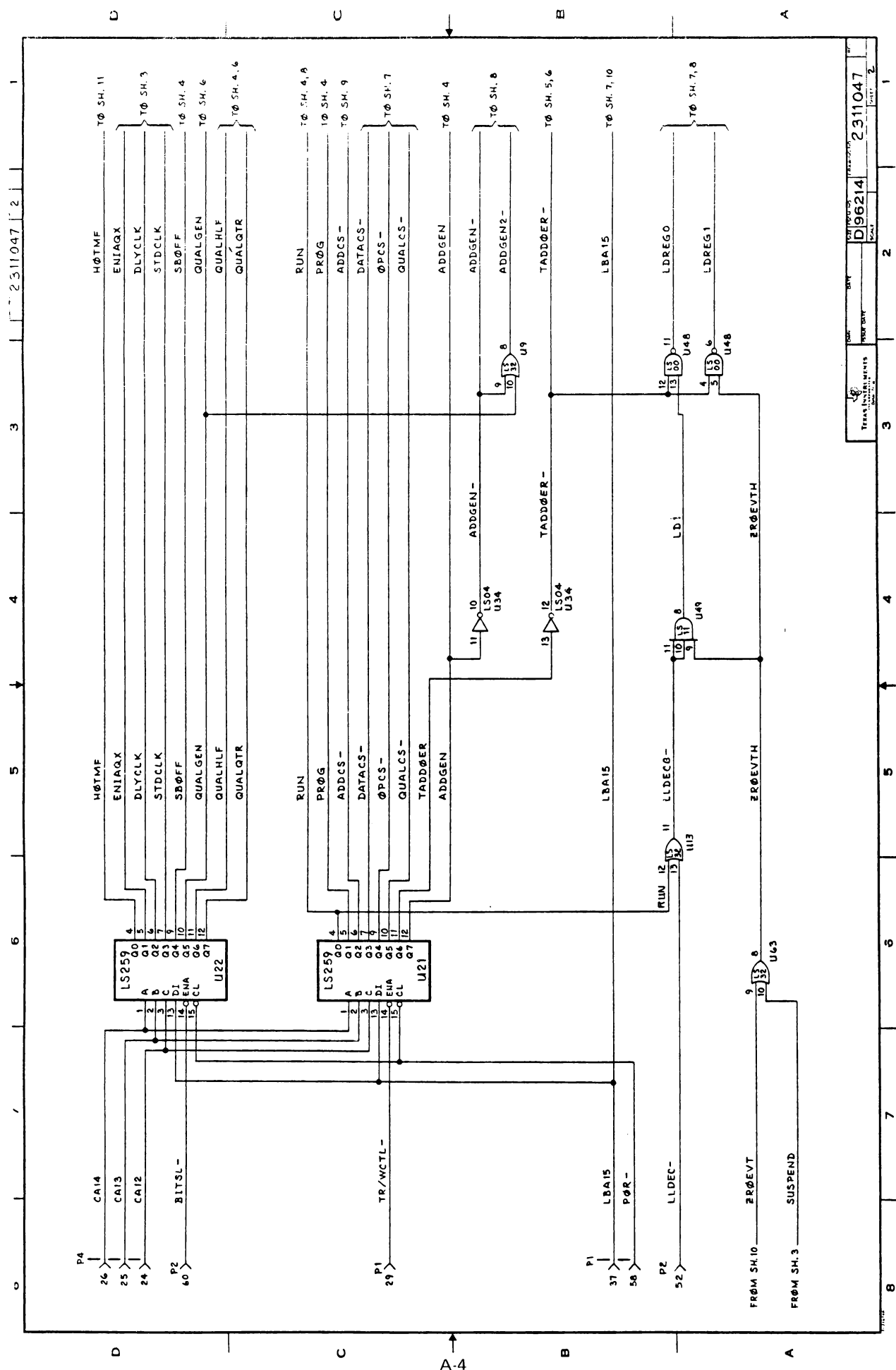

REV	DATE	BY	NO.
1			
2			
3			
4			
5			
6			
7			
8			
9			
10			
11			
12			
13			
14			
15			
16			
17			
18			
19			
20			
21			
22			
23			
24			
25			
26			
27			
28			
29			
30			
31			
32			
33			
34			
35			
36			
37			
38			
39			
40			
41			
42			
43			
44			
45			
46			
47			
48			
49			
50			
51			
52			
53			
54			
55			
56			
57			
58			
59			
60			
61			
62			
63			
64			
65			
66			
67			
68			
69			
70			
71			
72			
73			
74			
75			
76			
77			
78			
79			
80			
81			
82			
83			
84			
85			
86			
87			
88			
89			
90			
91			
92			
93			
94			
95			
96			
97			
98			
99			
100			

REV	DATE	BY	NO.
1			
2			
3			
4			
5			
6			
7			
8			
9			
10			
11			
12			
13			
14			
15			
16			
17			
18			
19			
20			
21			
22			
23			
24			
25			
26			
27			
28			
29			
30			
31			
32			
33			
34			
35			
36			
37			
38			
39			
40			
41			
42			
43			
44			
45			
46			
47			
48			
49			
50			
51			
52			
53			
54			
55			
56			
57			
58			
59			
60			
61			
62			
63			
64			
65			
66			
67			
68			
69			
70			
71			
72			
73			
74			
75			
76			
77			
78			
79			
80			
81			
82			
83			
84			
85			
86			
87			
88			
89			
90			
91			
92			
93			
94			
95			
96			
97			
98			
99			
100			

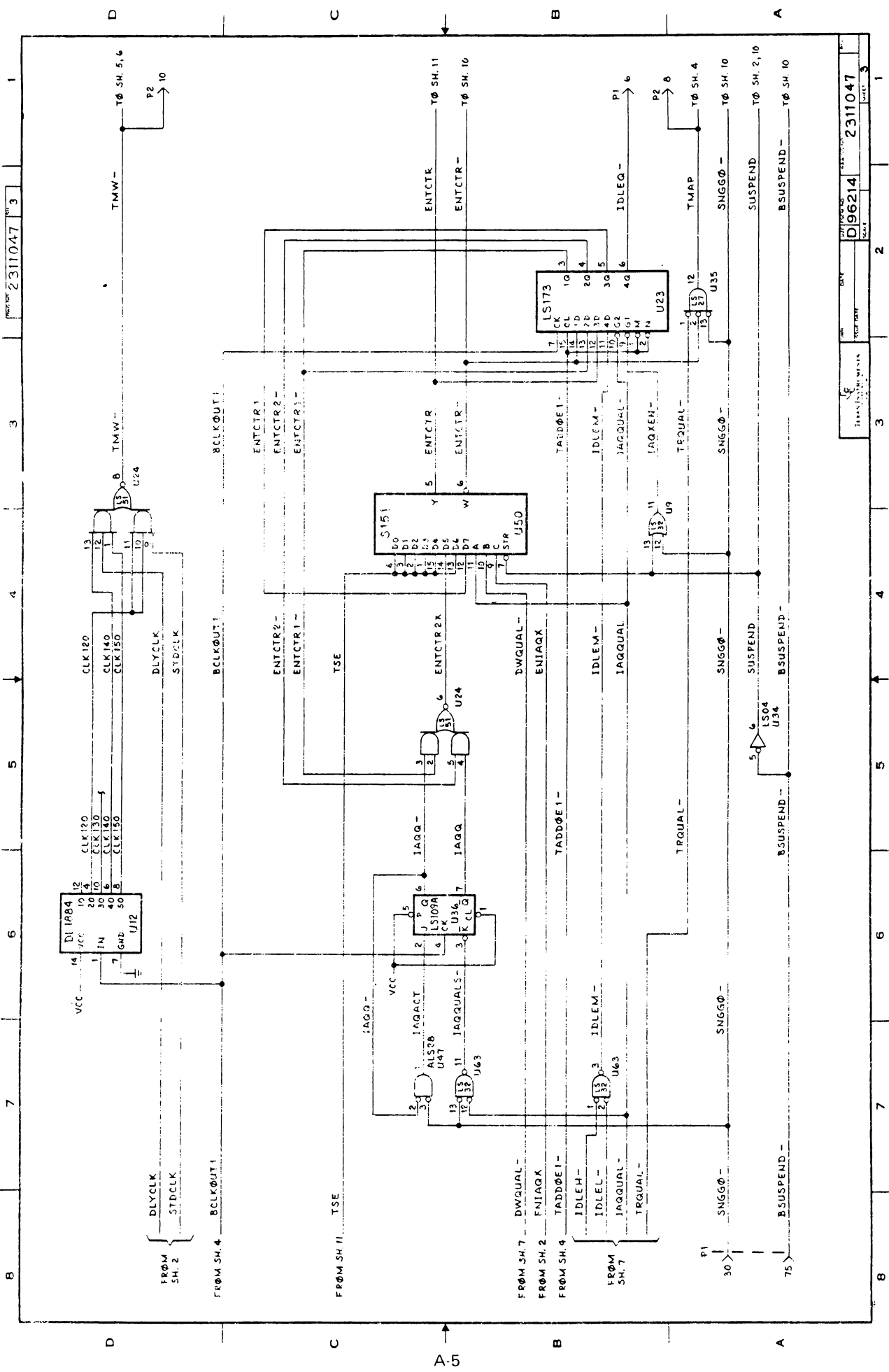

2311047

REV 3

B 1 3 4 5 6 7

REV	DATE	BY	APP'D	2311047
REV	DATE	BY	APP'D	D96214
REV	DATE	BY	APP'D	2311047

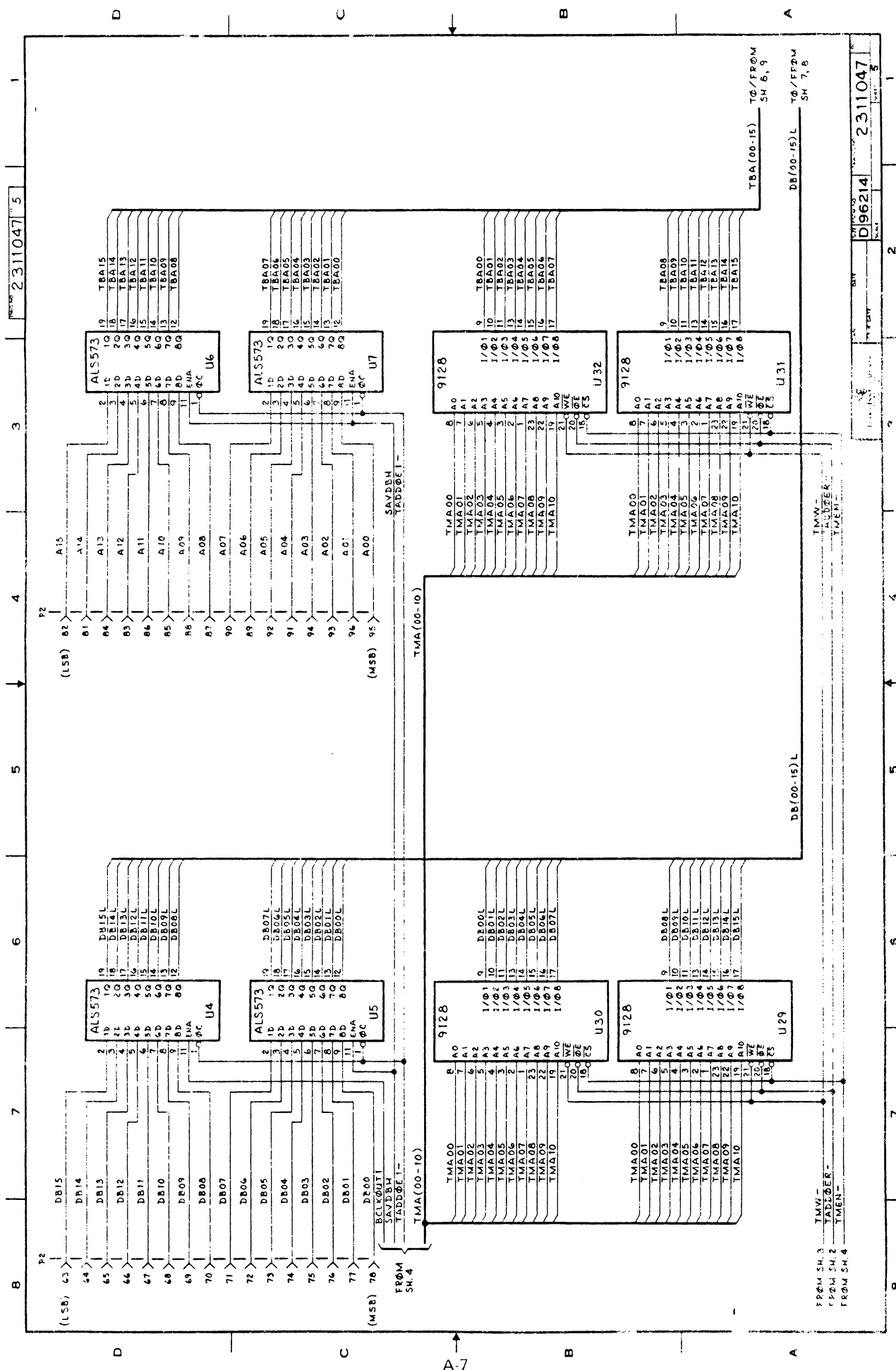

2311047 5

2311047 5

2311047 5

D96214

2311047

2311047

2311047

2311047

2311047

2311047

FROM SH. 3
FROM SH. 2
FROM SH. 4

T0/FROM
SH 6, 9

T0/FFROM
SH 7, 8

A-7

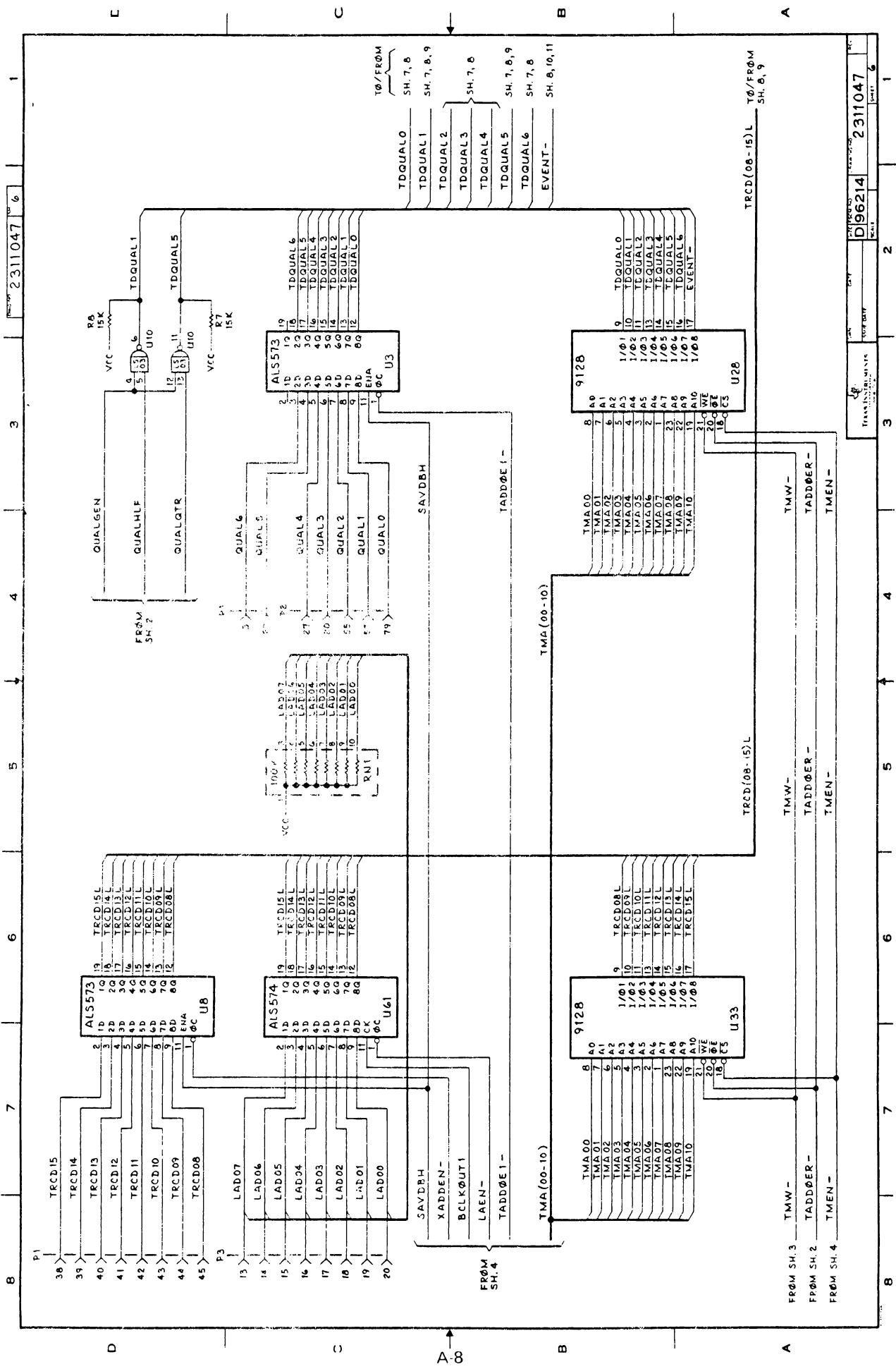

2311047 6

3

4

5

6

7

8

E

C

B

A

D

C

B

A

A-8

REV	DATE	BY	COMPANY	PROJECT
D96214	1987-07-09		TRANSACT SYSTEMS	2311047
				SHEET 6

2

3

4

5

6

7

8

FR0M SH. 2

FR0M SH. 3

FR0M SH. 4

FR0M SH. 2

FR0M SH. 2

FR0M SH. 4

FR0M SH. 4

FR0M SH. 4

TRCD15

TRCD14

TRCD13

TRCD12

TRCD11

TRCD10

TRCD09

TRCD08

LAD07

LAD06

LAD05

LAD04

LAD03

LAD02

LAD01

LAD00

SAVDBH

XADDEN-

BCLKOUT1

LAEN-

TADDER1-

TMA(00-10)

TMA00

TMA01

TMA02

TMA03

TMA04

TMA05

TMA06

TMA07

TMA08

TMA09

TMA10

TMW-

TADDER-

TMEN-

TRCD(08-15)L

TMW-

TADDER-

TMEN-

TQUAL6

TQUAL5

TQUAL4

TQUAL3

TQUAL2

TQUAL1

TQUAL0

EVENT-

TQUAL6

TQUAL5

TQUAL4

TQUAL3

TQUAL2

TQUAL1

TQUAL0

EVENT-

SH. 7, 8

SH. 7, 8, 9

SH. 7, 8

SH. 7, 8, 9

SH. 7, 8

SH. 8, 10, 11

SH. 7, 8

SH. 8, 9

TRCD(08-15)L

TRCD(08-15)L

TRCD(08-15)L

TRCD(08-15)L

TRCD(08-15)L

TRCD(08-15)L

TRCD(08-15)L

TRCD(08-15)L

U8

U61

U33

U3

U28

U33

U28

U33

R7

R7

R7

R7

R7

R7

R7

R7

U10

U10

U10

U10

U10

U10

U10

U10

C1

C1

C1

C1

C1

C1

C1

C1

P1

P1

P1

P1

P1

P1

P1

P1

P3

P3

P3

P3

P3

P3

P3

P3

P1

P1

P1

P1

P1

P1

P1

P1

P1

P1

P1

P1

P1

P1

P1

P1

P1

P1

P1

P1

P1

P1

P1

P1

P1

P1

P1

P1

P1

P1

P1

P1

P1

P1

P1

P1

P1

P1

P1

P1

P1

P1

P1

P1

P1

P1

P1

P1

P1

P1

P1

P1

P1

P1

P1

P1

P1

P1

P1

P1

P1

P1

P1

P1

P1

P1

P1

P1

P1

P1

P1

P1

P1

P1

P1

P1

P1

P1

P1

P1

P1

P1

P1

P1

P1

P1

P1

P1

P1

P1

P1

P1

P1

P1

P1

P1

P1

P1

P1

P1

P1

P1

P1

P1

P1

P1

P1

P1

P1

P1

P1

P1

P1

P1

P1

P1

P1

P1

P1

P1

P1

P1

P1

P1

P1

P1

P1

P1

P1

P1

P1

P1

P1

P1

P1

P1

P1

P1

P1

P1

P1

P1

P1

P1

P1

P1

P1

P1

P1

P1

P1

P1

P1

</

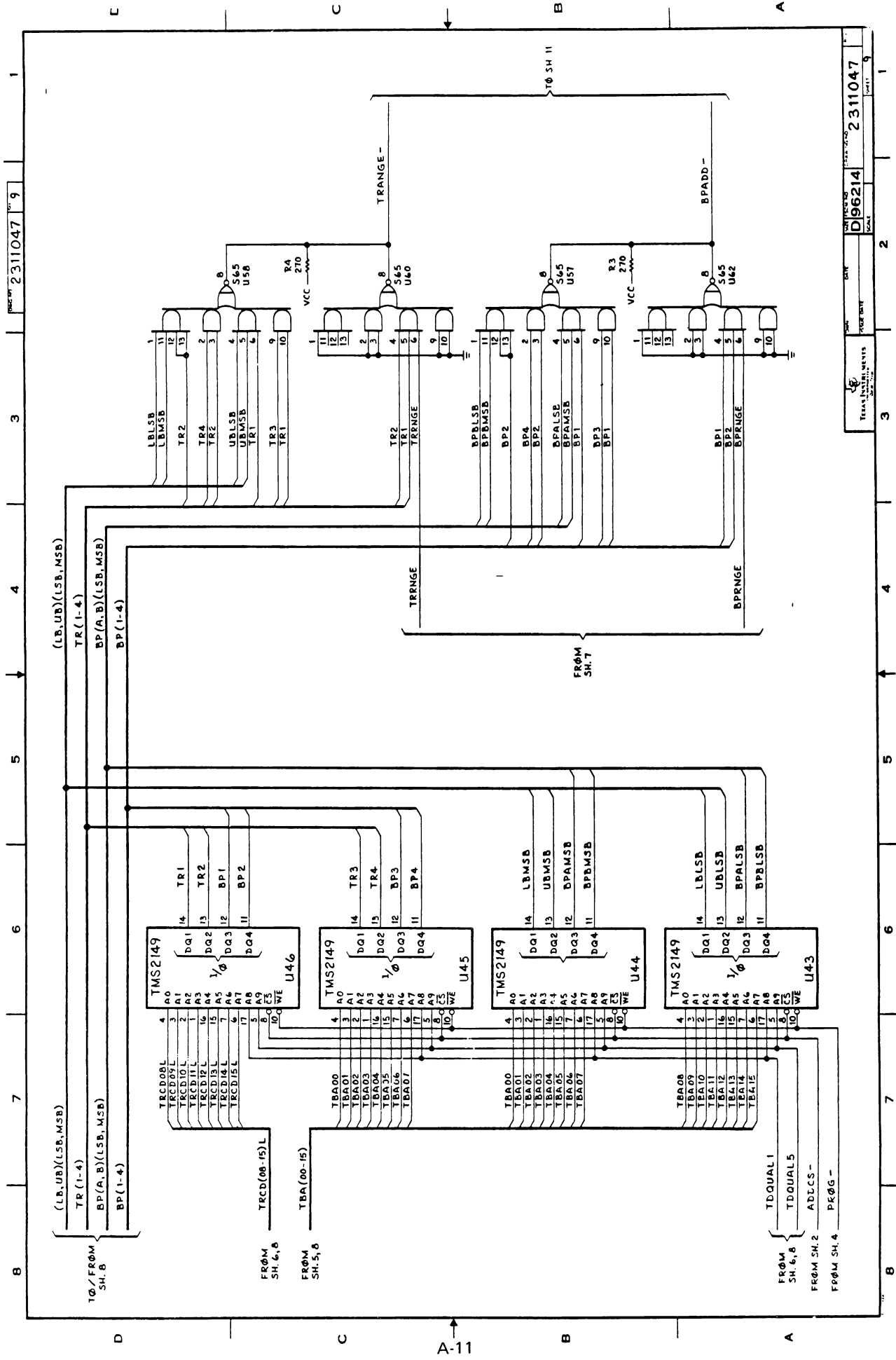

2311047 9

2311047 9

DJ96214

2311047

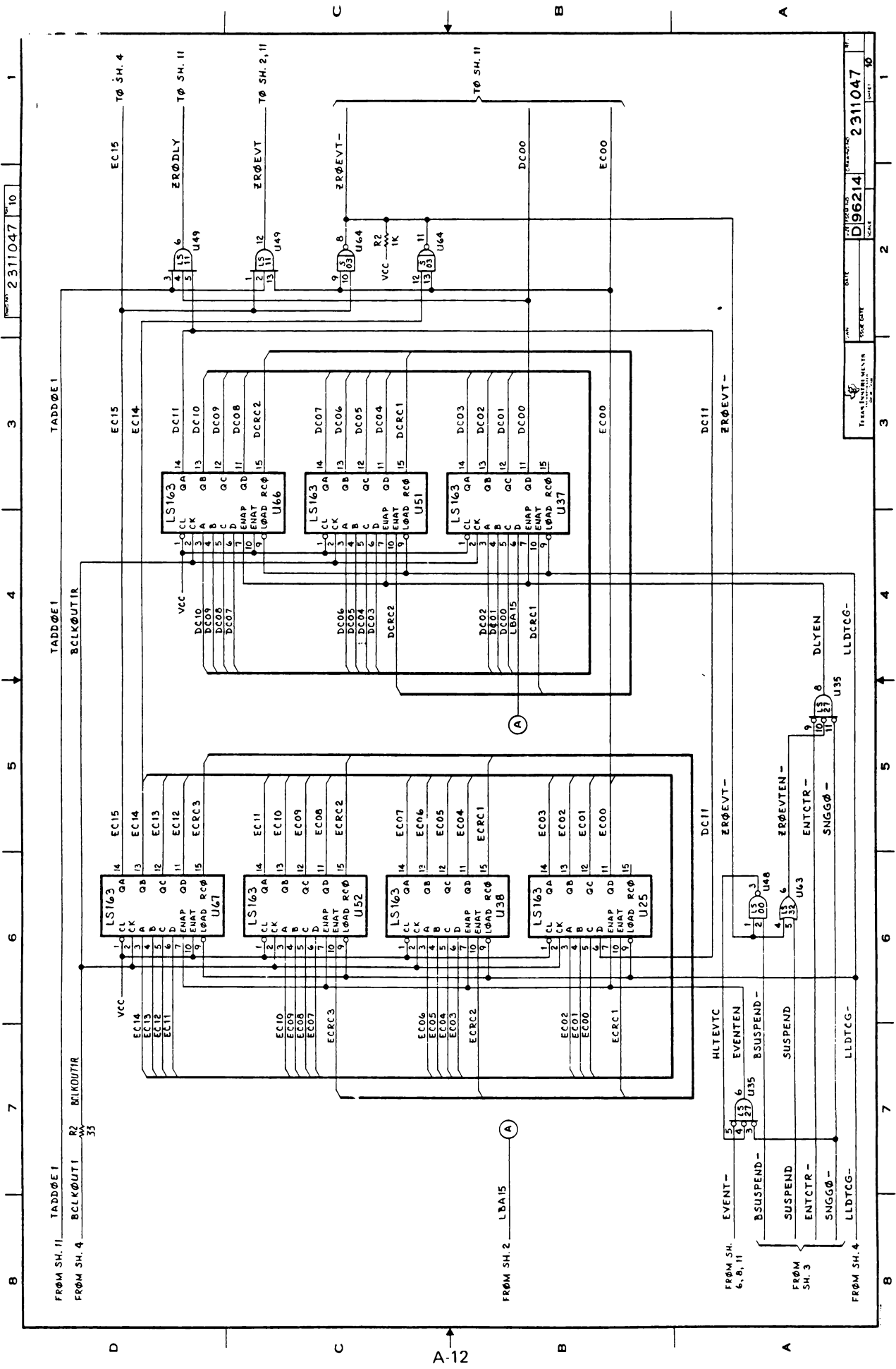

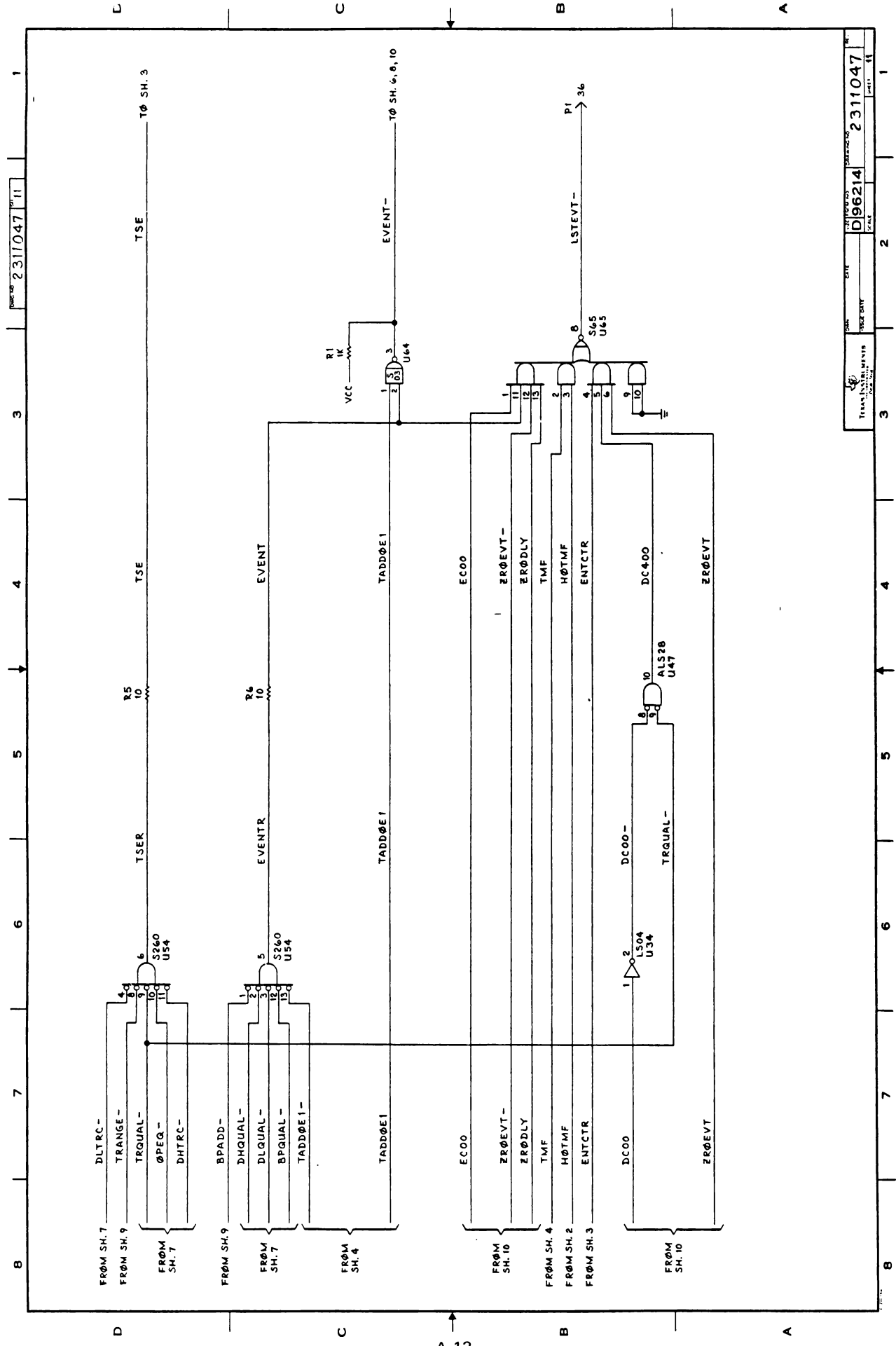

PROJECT 2311047

DATE	2311047
PROJECT	D96214
SCALE	1:1
REV.	1

FOLD



BUSINESS REPLY MAIL

FIRST CLASS PERMIT NO. 6189 HOUSTON, TEXAS

POSTAGE WILL BE PAID BY ADDRESSEE

**TEXAS INSTRUMENTS INCORPORATED
MOS MICROCOMPUTER SYSTEMS
P.O. BOX 1443
HOUSTON, TEXAS 77001**

**ATTENTION: TECHNICAL PUBLICATIONS
MAIL STATION 6440**

**NO POSTAGE
NECESSARY
IF MAILED
IN THE
UNITED STATES**



FOLD

October 1983
Revision *
1603442-9701
Printed in U.S.A.



Creating useful products
and services for you.

SPDU019